

# Mi-T-M<sup>®</sup> CORPORATION

8650 Enterprise Drive, Peosta IA 52068  
563-556-7484 / Fax 563-556-1235  
[www.mitm.com](http://www.mitm.com)

## PARTS LIST FOR *CM-1250-A/C*

Motor Specs:	1.5 HP / 1 Phase / 115 Volts
Pump Oil:	Mi-T-M #AW-4085-0016
Pump Oil Capacity:	6.5 oz.
Nozzle Size:	1.20 mm

This Parts Listing has been compiled for your benefit. You can be assured your Mi-T-M Cold Water Pressure Washer was constructed and designed with quality and performance in mind using over 25 years experience in the pressure washer business. Each component has been rigorously tested to insure the highest level of acceptance.

The contents of this Parts Listing are based on the latest product information available at the time of publication. Mi-T-M reserves the right to make changes in price, color, materials, equipment, specifications or models at any time without notice.

**WARNING**

THIS IS A PROFESSIONAL HIGH PRESSURE, COLD WATER PRESSURE WASHER. CAUTION SHOULD BE OBSERVED WHEN USING OR REPAIRING THIS UNIT! READ AND FOLLOW THE SAFETY WARNINGS LISTED BELOW BEFORE ATTEMPTING ANY REPAIRS ON THIS PRESSURE WASHER!

**SAFETY WARNINGS**

1. NEVER alter or modify the equipment. Be sure any accessory items and system components being used will withstand the pressure developed. Use only genuine Mi-T-M parts for repair of your pressure washer. Failure to do so can cause hazardous operating conditions and will VOID warranty.
2. NEVER make adjustments on machinery while the unit is connected to the engine without first removing the ignition cable from the spark plug. Turning over the machinery by hand during adjustment or cleaning might start the engine and machinery with it, causing serious injury to the operator.
3. Know how to stop and bleed pressures quickly. Be thoroughly familiar with controls.
4. Before servicing the unit, turn unit off, relieve the water pressure and allow the unit to cool down. Do not make repairs while the unit is running. Service in a clean, dry, flat area. Block the wheels to prevent the unit from moving. Be especially careful to properly dispose of any flammable materials.
5. After testing the machine, DO NOT leave the pressurized unit unattended. Shut off the unit and release trapped pressure before leaving.

# Table of Contents

FRAME ASSEMBLY FOR CM-1250-A/C .....	4
PUMP/MOTOR ASSEMBLY .....	6
GUN ASSEMBLY (16-0166) .....	8
LANCE ASSEMBLY (16-0170) .....	10
WIRING DIAGRAM .....	12
WIRING SCHEMATIC .....	13
NOTES .....	14-15

# FRAME ASSEMBLY FOR CM-1250-A/C

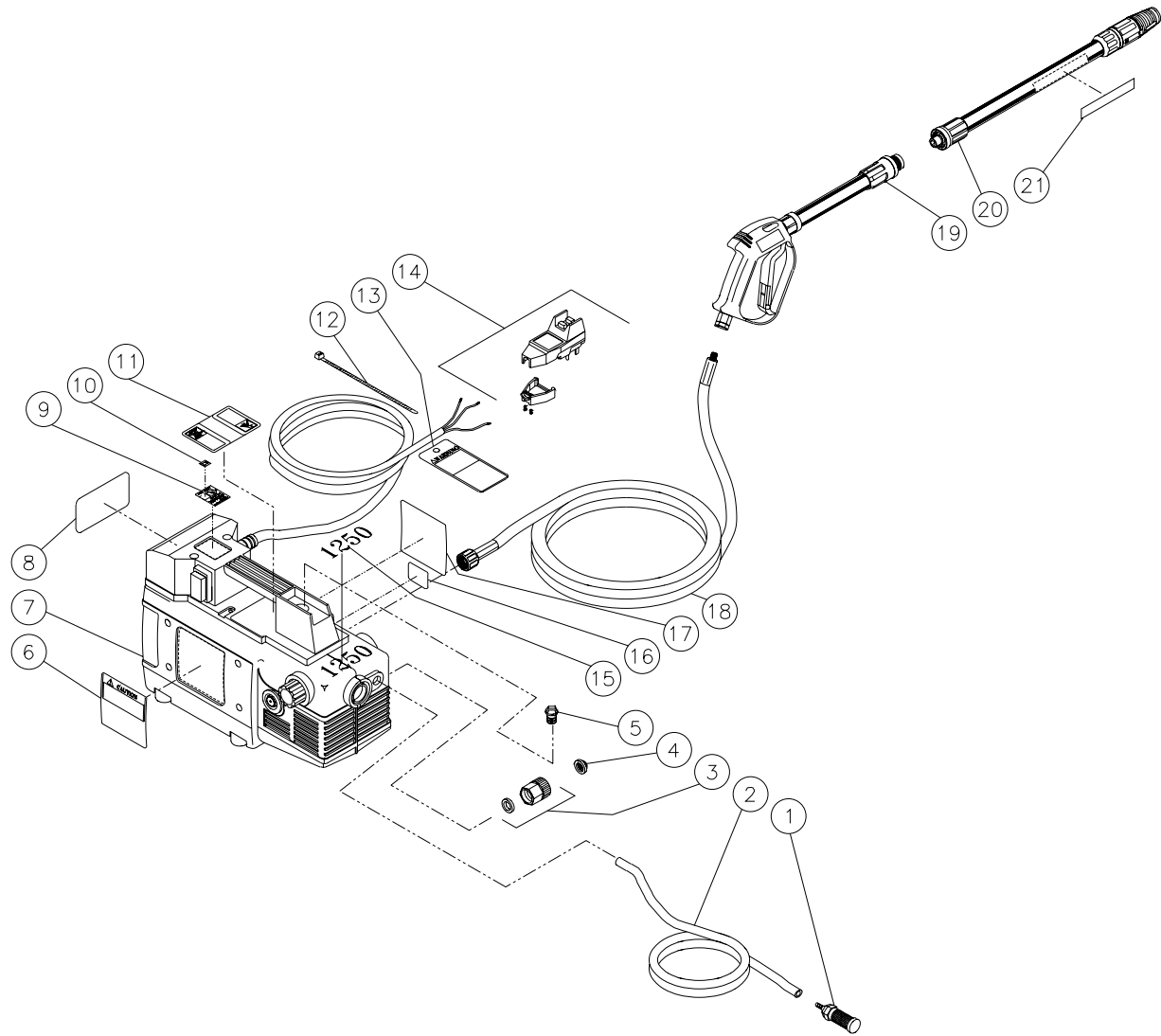

CM-1250-A/C-111201-RD

FRAME ASSEMBLY FOR CM-1250-A/C							
REF. #	DESCRIPTION	PART #	QTY.	REF. #	DESCRIPTION	PART #	QTY.
1	Detergent Strainer	19-0050	1	12	Cable Tie	33-0022	1
2	Detergent Hose w/Pump	15-0110	1	13	Hang Tag- U/L Warning (E/S) (CM-1250-A)	34-1014	1
3	Water Inlet Filter	19-0001	1	-	Hang Tag- C U/L Warning (E/F) (CM-1250-C)	34-0628	1
4	Garden Hose Swivel	23-0162	1	14	GFCI (15 Amp) w/o Power Cord	32-0364	1
5	Oil Cap	39-0066	1	-	GFCI (15 Amp) with Power Cord	32-0352	1
6	Decal- Caution/Important (E/S) (CM-1250-A)	34-1016	1	15	Decal- Die Cut	34-0707	1
-	Decal- Caution/Important (E/F) (CM-1250-C)	34-0640	1	16	Decal- Data Plate	N/A	1
7	Motor/Pump Assembly (See Exploded Drawing)	N/A Sep.	1	17	Decal- Warning: Risk of Electrocution (E/S) (CM-1250-A)	34-1021	1
8	Decal- Chore Master Logo	34-0706	1	-	Decal- Warning: Risk of Electrocution (E/F) (CM-1250-C)	34-0464	1
9	Decal- U/L Specs (CM-1250-A)	N/A	1	18	High Pressure Discharge Hose	15-0117	1
-	Decal- C U/L Specs Bilingual (CM-1250-C)	N/A	1	19	Gun w/Screw Lance	16-0166	1
10	Decal- Date Code	N/A	1	20	Variable Nozzle Assembly 1.20mm	16-0170	1
11	Decal- Warning: Risk of Injection/Explosion (E/S) (CM-1250-A)	34-1019	1	21	Decal- Variable Nozzle	34-0457	1
-	Decal- Warning: Risk of Injection/Explosion (E/F) (CM-1250-C)	34-0639	1	*Must Order in One Foot Lengths			

# PUMP/MOTOR ASSEMBLY

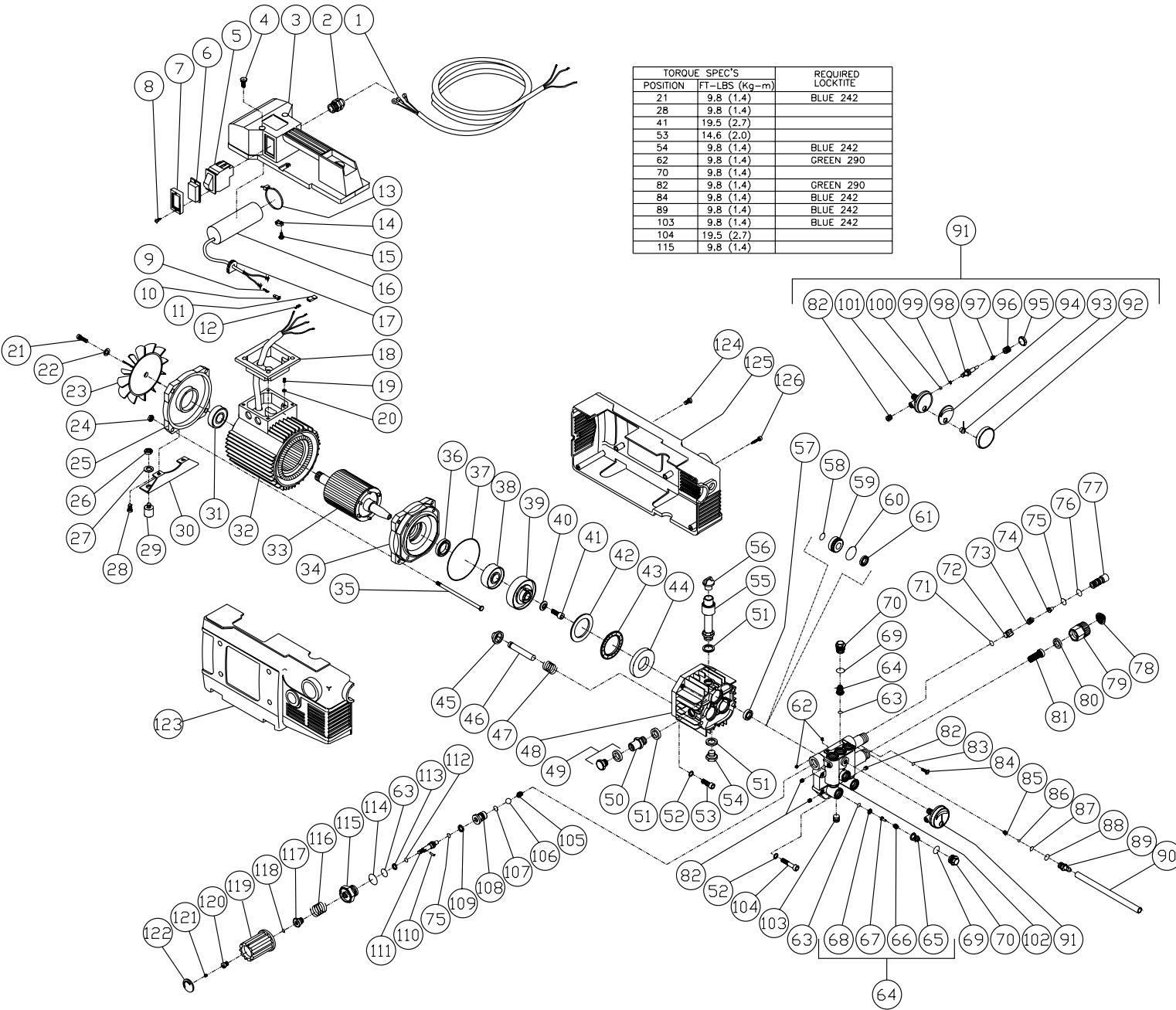

POSITION	TORQUE SPEC'S FT-LBS (Kg-m)	REQUIRED LOCKTITE
21	9.8 (1.4)	BLUE 242
28	9.8 (1.4)	
41	19.5 (2.7)	
53	14.6 (2.0)	
54	9.8 (1.4)	BLUE 242
62	9.8 (1.4)	GREEN 290
70	9.8 (1.4)	
82	9.8 (1.4)	GREEN 290
84	9.8 (1.4)	BLUE 242
89	9.8 (1.4)	BLUE 242
103	9.8 (1.4)	BLUE 242
104	19.5 (2.7)	
115	9.8 (1.4)	

3-0141-050602-

MOTOR/PUMP ASSEMBLY															
REF. #	DESCRIPTION	PART #	QTY.	REF. #	DESCRIPTION	PART #	QTY.	REF. #	DESCRIPTION	PART #	QTY.	REF. #	DESCRIPTION	PART #	QTY.
1	GFCI (15 Amp) w/o Power Cord	32-0364	1	36	Oil Seal	25-0244	1	72	Unloader Check Valve (See 70-0108)	N/A Sep.	1	108	Valve Seat (See 70-0089)	N/A Sep.	1
-	GFCI (15 Amp) with Power Cord	32-0352	1	37	O-ring	25-0243	1	73	Check Valve Spring (See 70-0108)	N/A Sep.	1	109	Back-up Ring (See 70-0089)	N/A Sep.	1
2	Strain Relief	9-0051	1	38	Ball Bearing	48-0033	1	74	Injector Nozzle (See 70-0108)	N/A Sep.	1	110	Roll Pin (See 70-0089)	N/A Sep.	1
3	Handle	62-0060	1	39	Wobble Plate 9"	46-0467	1	75	O-ring (See 70-0108)	N/A Sep.	2	111	Piston By-pass Valve (See 70-0089)	N/A Sep.	1
4	Screw	27-8196	4	40	Washer	28-0133	1	76	O-ring (See 70-0108)	N/A Sep.	1	112	O-ring (See 70-0089)	N/A Sep.	1
5	Switch	22-0184	1	41	Screw	27-8195	1	77	Injector Bushing (See 70-0108)	N/A Sep.	1	113	Back-up Ring (See 70-0089)	N/A Sep.	1
6	Switch Protector (See 70-0067)	N/A Sep.	1	42	Bearing Disk-Rear	48-0035	1	78	Garden Hose Filter	19-0001	1	114	O-ring (See 70-0089)	N/A Sep.	1
7	Switch Protector Frame (See 70-0067)	N/A Sep.	1	43	Bearing	48-0030	1	79	Garden Hose Swivel	23-0162	1	115	Body By-pass Valve (See 70-0089)	N/A Sep.	1
8	Screw (See 70-0067)	N/A Sep.	2	44	Bearing Disk - Front	48-0032	1	80	Garden Hose Gasket	26-0166	1	116	Pressure Reg. Spring (See 70-0089)	N/A Sep.	1
9	Electric Connector (See 70-0105)	N/A Sep.	2	45	Piston Spring Retainer	46-0362	3	81	Filter Inlet	19-0061	1	117	Pressure Reg. Screw (See 70-0089)	N/A Sep.	1
10	Electric Connection Protector - Female (See 70-0105)	N/A Sep.	2	46	Piston	46-0363	3	82	Screw	27-8197	4	118	Snap Ring (See 70-0089)	N/A Sep.	1
11	Electric Connection Protector - Male	N/A	4	47	Piston Spring	49-0081	3	83	O-ring	25-0357	1	119	Pressure Reg. Knob (See 70-0089)	N/A Sep.	1
12	Electric Connector - Female	N/A	4	48	Pump Housing	48-0031	1	84	Screw	27-8866	1	120	Screw (See 70-0089)	N/A Sep.	1
13	Plastic Wire Tie (See 70-0105)	N/A Sep.	1	49	Oil Sight Glass (See 70-0082)	N/A Sep.	1	85	Spring for Detergent Injector (See 70-0102)	N/A Sep.	1	121	Set Screw (See 70-0089)	N/A Sep.	1
14	Clip (See 70-0105)	N/A Sep.	1	50	Oil Sight Glass Support (See 70-0082)	N/A Sep.	1	86	Ball for Detergent Injector See 70-0102)	N/A Sep.	1	122	Cap - Red	7-0088	1
15	Screw (See 70-0105)	N/A Sep.	1	51	Gasket	26-0168	3	87	O-ring (See 70-0102)	N/A Sep.	1	123	Cover-Right	62-0062	1
16	Capacitor	46-0345	1	52	Lockwasher	29-0154	8	88	O-ring (See 70-0102)	N/A Sep.	1	124	Screw	27-8863	8
17	Grommet (See 70-0105)	N/A Sep.	1	53	Bolt	27-8194	4	89	Hose Barb	33-0151	1	125	Cover-Left	62-0061	1
18	Gasket	26-0165	1	54	Oil Drain Plug (See 70-0083)	N/A Sep.	1	90	Detergent Hose *(Four Feet Required)	15-0021	1	126	Screw	27-8193	4
19	Screw	27-8187	1	55	Extension Oil Tube	46-0351	1	91	Pressure Indicator Complete (Inc. 2, 92-101)	22-0210	1		Oil Seal Kit (Inc. 3 each 57)	70-0001	
20	Washer	28-0061	1	56	Oil Fill Cap	39-0066	1	92	Pressure Indicator Cover (See 22-0210)	N/A Sep.	1		Switch Cover Kit (Includes 6-8)	70-0067	
21	Screw	27-8864	1	57	Oil Seal	26-0163	3	93	Pressure Indicator Needle (See 22-0210)	N/A Sep.	1		Garden Hose Swivel Kit (Inc. 79, 80)	70-0068	
22	Washer	28-1022	2	58	O-ring (See 70-0118 or 70-0084)	N/A Sep.	3	94	Pressure Ind. Dialplate (See 22-0210)	N/A Sep.	1		Oil Tube Assy (Inc. 51, 55)	70-0081	
23	Motor Fan	52-0043	1	59	Packing Retainer	9-0050	3	95	Locknut (See 22-0210)	N/A Sep.	1		Oil Sight Glass Kit (Inc. 49-51)	70-0082	
24	Nut	30-3003	4	60	O-ring (See 70-0118 or 70-0084)	N/A Sep.	3	96	Adjusting Screw (See 22-0210)	N/A Sep.	1		Oil Drain Plug Kit (Inc. 51, 54)	70-0083	
25	Motor Flange - Rear	52-0020	1	61	Pressure Seal (See 70-0084)	N/A Sep.	3	97	Spring (See 22-0210)	N/A Sep.	1		Pump Packing Kit (Inc. 58-61)	70-0084	
26	Nut	30-3024	4	62	Screw	27-8821	2	98	Pressure Indicator Piston (See 22-0210)	N/A Sep.	1		Valve Assy (Inc. 63, 64)	70-0086	
27	Washer	28-0132	4	63	O-ring (See 70-0086)	N/A Sep.	7	99	Back-up Ring (See 22-0210)	N/A Sep.	1		Manifold Bolt Kit (Inc. 4 each 52, 104)	70-0088	
28	Screw	27-8190	4	64	Valve Complete (Inc. 65-68) (See 70-0086)	N/A Sep.	6	100	O-ring (See 22-0210)	N/A Sep.	1		Manifold Assy (Inc. 58-89, 102-103, 105-122)	70-0089	
29	Rubber Foot	14-0055	4	65	Valve Cage (See 70-0086)	N/A Sep.	6	101	Pressure Gauge Body (See 22-0210)	N/A Sep.	1		Injector Repair Kit (Inc. 85-88)	70-0102	
30	Angle Support for Motor	20-0318	2	66	Valve Spring (See 70-0086)	N/A Sep.	6	102	Pump Manifold	46-0649	1		Capacitor Assy (Inc. 9-10, 13-17)	70-0105	
31	Ball Bearing	48-0029	1	67	Valve (See 70-0086)	N/A Sep.	6	103	Screw	27-8198	1		Unloader Check Valve Kit (Inc. 71-77)	70-0108	
32	Stator	52-0022	1	68	Valve Seat (See 70-0086)	N/A Sep.	6	104	Screw (See 70-0088)	N/A Sep.	4		Pump Packing Kit (Inc. 3 each 58, 60, 61)	70-0118	
33	Rotor	52-0044	1	69	O-ring	25-0335	6	105	Spring (See 70-0089)	N/A Sep.	1		Unloader Assy (Inc. 63, 71-73, 105-122)	70-0138	
34	Motor Flange - Front	52-0025	1	70	Valve Plug	46-0628	6	106	Ball (See 70-0089)	N/A Sep.	1		Valve Cap Assy (Inc. 3 each 69-70)	70-0145	
35	Screw	27-8188	4	71	O-ring (See 70-0108)	N/A Sep.	1	107	O-ring (See 70-0089)	N/A Sep.	1		Unloader Seat Kit (Inc. 105-108)	70-0192	

\*Must Order in One Foot Lengths

# WIRING DIAGRAM

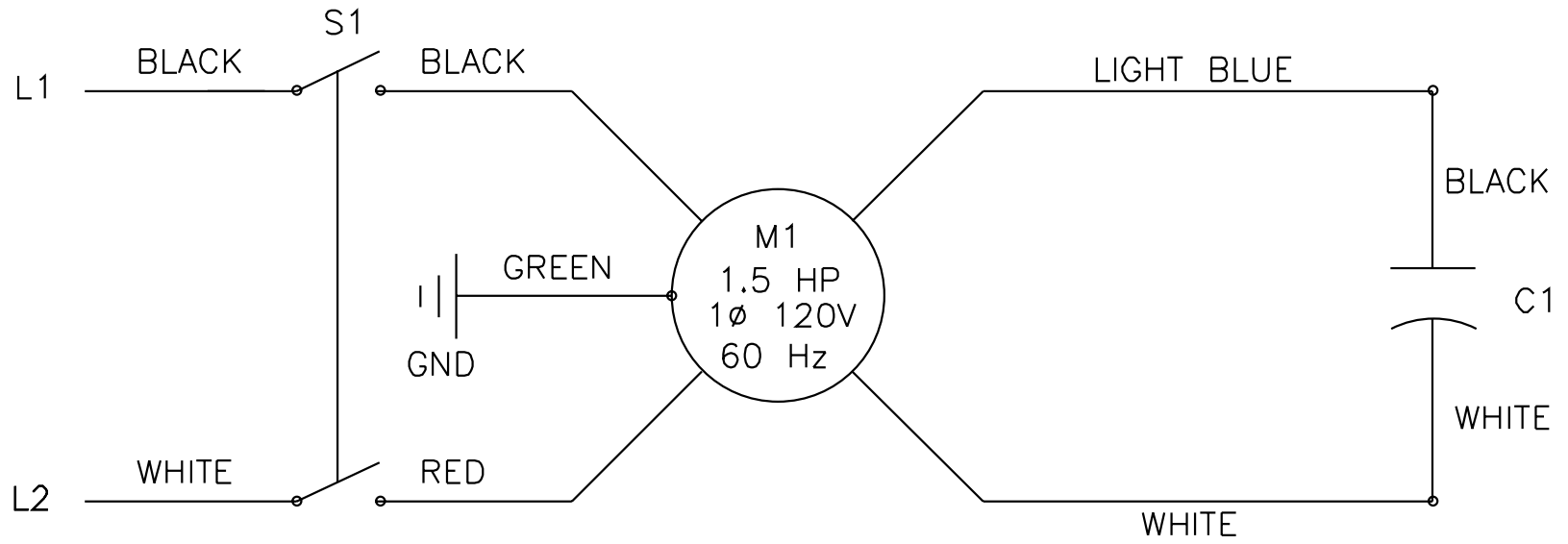



# WIRING SCHEMATIC

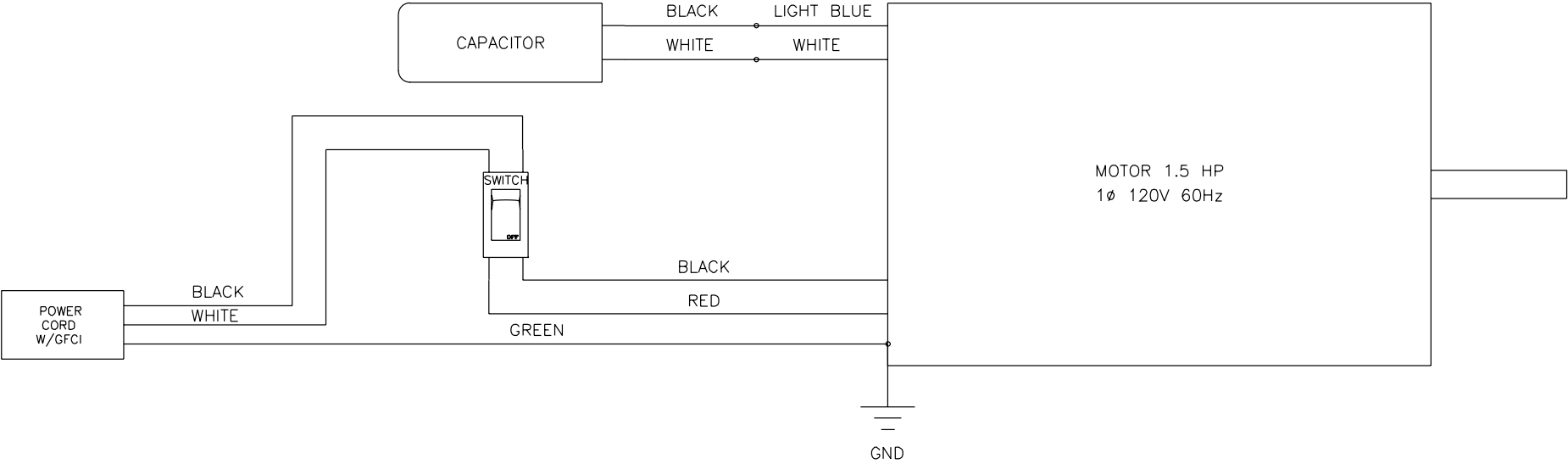

OMFP056-012396-JTR