

**RYOBI**  
**Pressure Washer**  
**Manufacturing No. 090079285**  
**Item No. RY803100**  
**Replacement Parts List**

RYOBI PRESSURE WASHER - ITEM NO. RY803100

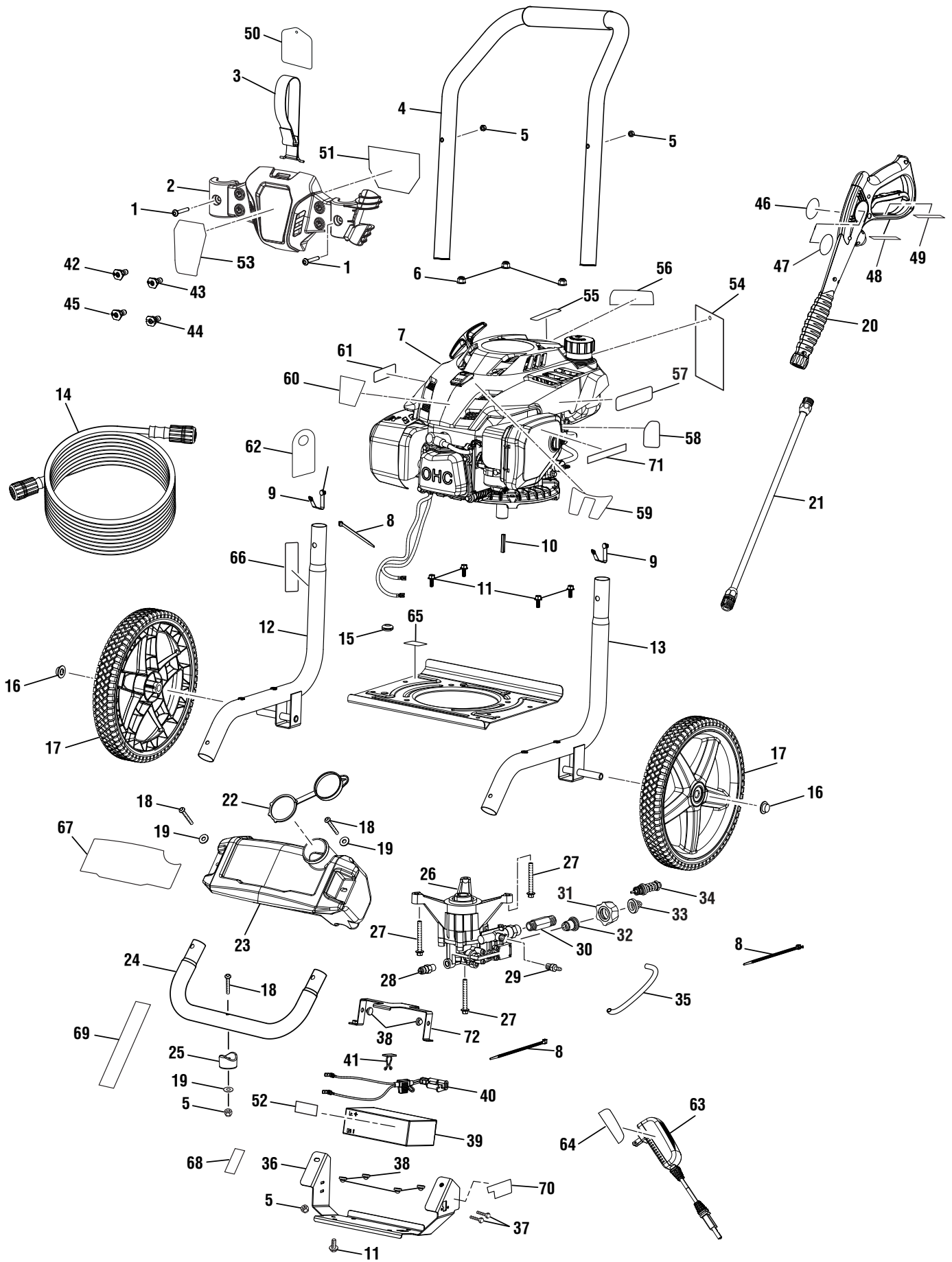

## RYOBI PRESSURE WASHER – ITEM NO. RY803100

The item and manufacturing number will be found on a label attached to the engine plate. Always mention the item and manufacturing number in all correspondence regarding your **PRESSURE WASHER** or when ordering replacement parts.

KEY NO.	PART NUMBER	DESCRIPTION	QTY	KEY NO.	PART NUMBER	DESCRIPTION	QTY
1	661834004	Bolt (M6 x 42 mm, T30 Torx Pan Hd.).....	2	38	570733003	Rubber Isolator .....	6
2	310673029	Hose And Nozzle Assembly.....	1	39	750400007	Battery.....	1
3	308350003	Hose Holder Strap .....	1	40	290435021	Battery & Charger Wire Harness.....	1
4	308638060	Handle Assembly w/ Foam Grip .....	1	41	900333020	Cable Tie .....	1
5	678610006	Lock Nut (M6 x 1).....	4	42	308699012	25° Nozzle.....	1
6	678774002	Flange Lock Nut (M8 x 1.25).....	3	43	308700012	40° Nozzle.....	1
7	Note A	Engine (Subaru 190V, E-Start).....	1	44	308697012	0° Nozzle.....	1
8	900333015	Wire Tie .....	3	45	308706011	Soap Nozzle.....	1
9	308421004	Handle Spring Clip .....	2	46	940786035	Label (Trigger Handle Logo).....	1
10	678041006	Output Shaft Key ( 35 mm) .....	1	47	940654084	Label (Trigger Handle Warning).....	1
11	661505020	Flange Bolt (M6 x 16 mm, Hex Hd.).....	5	48	940786020	Label (Trigger Handle Specifications) .....	1
12	310703012	Main Frame Assembly (Left) (Inc. Key No. 9).....	1	49	940654228	Label (Trigger Handle Warning, French & Spanish).....	1
13	310704013	Main Frame Assembly (Right) (Inc. Key No. 9) .....	1	50	961039005	Standard Nozzle Hangtag.....	1
14	308835006	Hose .....	1	51	940617163	Quick Start Label .....	1
15	561383004	Rubber Grommet .....	1	52	941155002	Battery Replacement Label .....	1
16	679957001	Push Cap Nut.....	2	53	940779163	Performance Label.....	1
17	308451053	Wheel .....	2	54	940473012	Warning Hangtag .....	1
18	661503015	Screw (M6 x 1 x 48 mm, T30 Torx Pan Hd.) .....	3	55	940873007	E85 Label .....	1
19	638128004	Washer (1/4 in.) .....	3	56	940971069	Engine Warning Label .....	1
20	308760019	Trigger Handle Assembly (Inc. Keys Nos. 47-48) .....	1	57	941550008	Choke Label.....	1
21	308506006	Wand Assembly .....	1	58	940698037	Fuel Valve & Choke Label .....	1
22	310650004	Soap Tank Cap.....	1	59	940698038	On/Off Label.....	1
23	580875019	Soap Tank .....	1	60	940608010	Subaru Label.....	1
24	310742028	Front Frame Assembly (Inc. Keys Nos. 5, 18-19 & 25) .....	1	61	940680074	Hot Surface Label .....	1
25	570554002	Wear Pad.....	1	62	940889002	Oil Dipstick Hangtag .....	1
26	308653072	Pump (Inc. Keys Nos. 29-34) .....	1	63	140173025	Battery Charger.....	1
27	660962003	Flange Bolt (M8 x 1.25 x 60 mm, Hex Hd.).....	3	64	940780027	Battery Charger Label.....	1
28	678169004	Thermal Release Valve.....	1	65	940872025	Oil Fill Location Label.....	1
29	308452002	Soap Injector Kit .....	1	66	940947016	Combustion Warning Label .....	1
30	308862003	Outlet Tube.....	1	67	940608024	Detergent Tank Label .....	1
31	310993003	Inlet Filter Adapter.....	1	68	940473025	Battery Terminal Connector Flag .....	1
32	642058001	Inlet Filter Connector .....	1	69	940473026	Charging Label Wrap .....	1
33	308662001	Filter Screen .....	1	70	940780081	Battery Bracket Label (Maintainer).....	1
34	310924003	Unloader Valve Assembly .....	1	71	941486008	Inquiries Label.....	1
35	570728010	Chemical Siphon Tube.....	1	72	636694001	Battery Hold Down Bracket .....	1
36	678714018	Battery Mount Bracket.....	1	<b>Not Shown:</b>			
37	660923018	Screw (M4 x 12 mm, T20 Torx Pan Hd.) .....	2	991000659	Operator's Manual		
				991000660	Assembly Guide		
				519314001	Funnel		

**NOTE A:** OWT Industries, Inc., will not provide complete engines as replacement parts. Engines are covered through the engine manufacturer's warranty. Consult the accompanying engine manual or contact our service department for assistance.

**TECHTRONIC INDUSTRIES POWER EQUIPMENT**

1428 Pearman Dairy Road, Anderson, SC 29625 USA  
1-800-860-4050 • [www.ryobitools.com](http://www.ryobitools.com)